

CALIBER[®]

F-7500

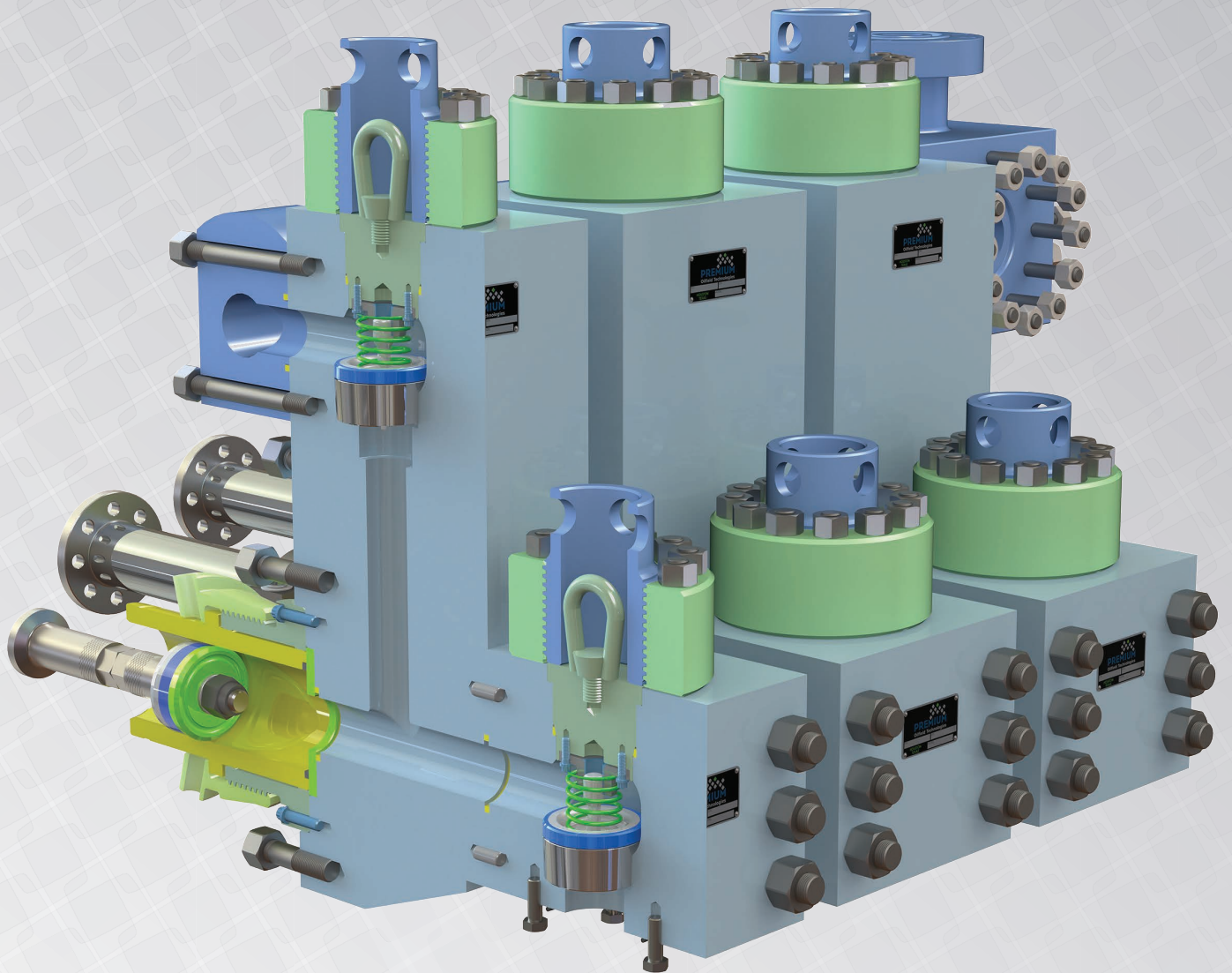

PREMIUM[®]
Oilfield Technologies

Premium Oilfield Technologies offers a complete line of fluid end modules and components that are manufactured to OEM specifications and interchangeability. We offer 7500 psi designs for all major pump configurations. **Our Caliber® modules start with high-tensile strength steel and are machined to precise engineering tolerances.** Each forging is machined and heat treated to maintain the best physical properties inside the module and on the surface, thus minimizing washing and stress cracking.

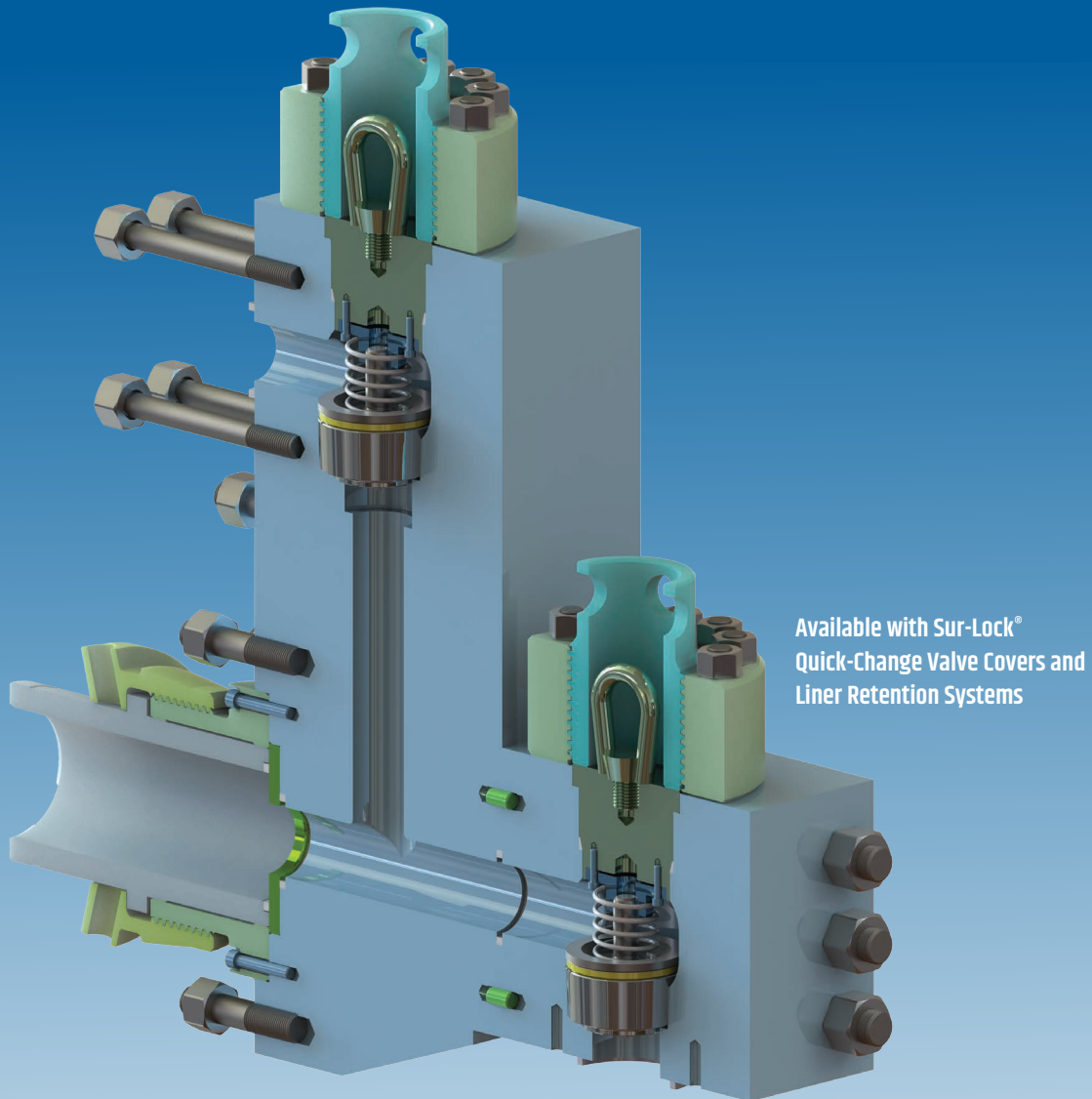

Available with Sur-Lock®
Quick-Change Valve Covers and
Liner Retention Systems

Caliber F-7500 2-Piece Design

F-1600 Compatible Fluid End Modules

The 2-piece 7500 psi fluid end module for the F-1600 pumps is based on industry-standard design and is 100% compatible with parts from the OEM and other manufacturers.

EXPENDABLES AND PERFORMANCE

Size (inches)	Liners		Liner Gaskets	
	Caliber® Steel Liner	Patriot™ Zirconia Liner	Nitrile Rubber	Urethane
4"	100-51C40-00	101-51Z40-00	202-50N50-00	202-50U50-00
4-1/2"	100-51C44-00	101-51Z44-00	202-50N50-00	202-50U50-00
5"	100-51C50-00	101-51Z50-00	202-50N50-00	202-50U50-00
5-1/2"	100-51C54-00	101-51Z54-00	202-50N54-00	202-50U54-00
6"	100-51C60-00	101-51Z60-00	202-50N60-00	202-50U60-00
6-1/2"	100-51C64-00	101-51Z64-00	202-50N64-00	202-50U64-00
7"	100-51C70-00	101-51Z70-00	202-50N70-00	202-50U70-00

¼" sizes available on request

7,500 PSI Operating Pressure		Strokes Per Min.	120	110	100	90	80	70	60	50	40
12" STROKE		Input HP	1600	1467	1333	1200	1067	933	800	667	533
Piston Size	Discharge Pressure Rating	Output Gal/Rev	OUTPUT - Gallons Per Minute (L/min)*								
6-3/4"	3,688	5.577	669 (2533)	613 (2322)	558 (2111)	502 (1900)	446 (1689)	390 (1478)	335 (1267)	279 (1055)	223 (844)
6-1/2"	3,977	5.171	621 (2349)	569 (2153)	517 (1957)	465 (1762)	414 (1566)	362 (1370)	310 (1174)	259 (979)	207 (783)
6-1/4"	4,302	4.781	574 (2172)	526 (1991)	478 (1810)	430 (1629)	383 (1448)	335 (1267)	287 (1086)	239 (905)	191 (724)
6"	4,668	4.406	529 (2001)	485 (1835)	441 (1668)	397 (1501)	353 (1334)	308 (1167)	264 (1001)	220 (834)	176 (667)
5-3/4"	5,082	4.047	486 (1838)	445 (1685)	405 (1532)	364 (1379)	324 (1225)	283 (1072)	243 (919)	202 (766)	162 (613)
5-1/2"	5,555	3.703	444 (1682)	407 (1542)	370 (1401)	333 (1261)	296 (1121)	259 (981)	222 (841)	185 (701)	148 (561)
5-1/4"	6,097	3.374	405 (1532)	371 (1405)	337 (1277)	304 (1149)	270 (1022)	236 (894)	202 (766)	169 (638)	135 (511)
5"	6,722	3.060	367 (1390)	337 (1274)	306 (1158)	275 (1042)	245 (927)	214 (811)	184 (695)	153 (579)	122 (463)
4-3/4"	7,448	2.762	331 (1254)	304 (1150)	276 (1045)	249 (941)	221 (836)	193 (732)	166 (627)	138 (523)	110 (418)
4-1/2"	7,500	2.479	297 (1126)	273 (1032)	248 (938)	223 (844)	198 (751)	174 (657)	149 (563)	124 (469)	99 (375)
4-1/4"	7,500	2.211	265 (1004)	243 (920)	221 (837)	199 (753)	177 (669)	155 (586)	133 (502)	111 (418)	88 (335)
4"	7,500	1.958	235 (890)	215 (815)	196 (741)	176 (667)	157 (593)	137 (519)	118 (445)	98 (371)	78 (297)

Max PSI calculations do not exceed maximum fluid end pressure testing.

*Based on 100% volumetric efficiency and 90% mechanical efficiency

OEM STYLE MODULE COMPONENTS

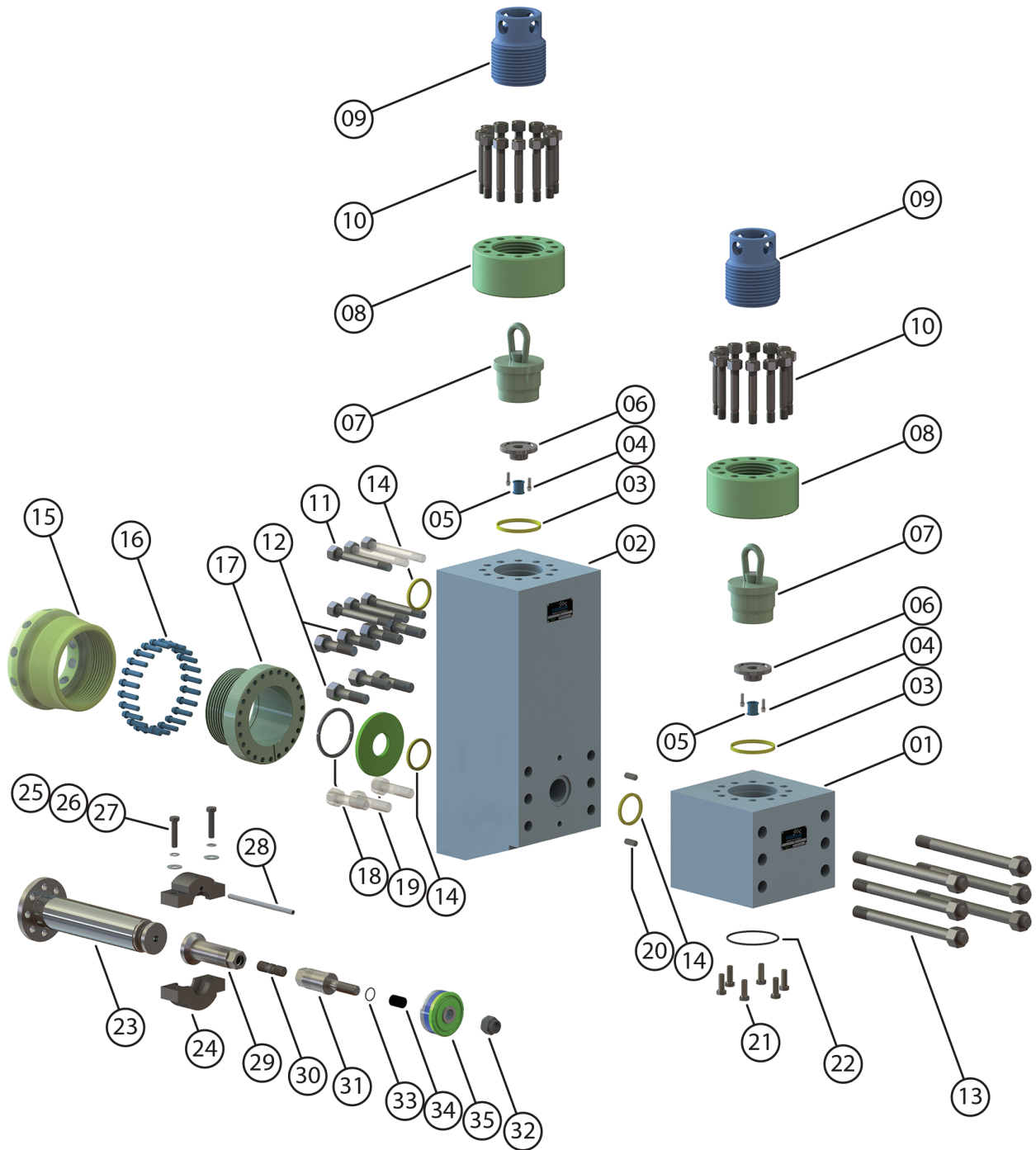

MODULE COMPONENTS

Item No.	Part Number	OEM Part Number	Part Description	Torque Ft. Lbs.	Qty. Per Pump
	140-24S75-00		Fluid End Assembly (3- Module Assemblies, 1- Discharge Manifold, Studs, Nuts, and Gaskets)		1
	142-24S75-00	8404-25A	Module Assembly, Complete with Accessories (complete with 1-17 and 19-21)		3
1	144-24S75-00	8404-26	Module, Suction (studded only)		3
2	145-24S75-00	8404-27	Module, Discharge (studded only)		3
3	204-01U15-00	P115	Seal, Valve Cover - Urethane (available in NBR)		6
4	170-04B13-06	4018-18	Capscrew, Valve Guide - 1/2-13 X 1-1/2 12PT ASTM 193 B16	80	12
5	206-44U07-00	47001U	Bushing, Valve Guide - Urethane (available in NBR)		6
6	154-51S75-00	4788-25R	Valve Guide with Bushing (complete with 5)		6
7	153-51S75-00	4690-25A	Plug, Valve Cover (complete with 4,5, and 6)		6
8	151-51S75-00	4488-25	Valve Cover Flange/Threaded Ring		6
9	152-51S75-00	4588-25	Screw Gland		6
10	170-12A07-06S	4015-2	Stud- 1-1/4 - 7 X 9-1/2 B7, Valve Cover with Hvy Hex Nut 170-12A07-00	970	72
11	170-12A07-15S	4019-60	Stud, 1-1/4 - 7 X 12.25 B7, Discharge Manifold with Hvy Hex Nut 170-12A07-00	1098	18
12	170-14A08-15S	4017-33	Stud, 1-1/2-8 X 7-1/2 B7, Power End with Hvy Hex Nut 170-14A08-00	875	30
13	170-16A08-15S	4019-61	Stud, 1-3/4-8 X 22 1/2 B7, Suction Module with Hvy Hex Nut 170-16A08-00	3299	18
14	202-00U88-00	2988	Seal, Module/Wear Plate - Urethane (available in NBR)		3
15	182-51S00-00	6590-25	Nut, Liner Retainer Flange/Bushing		3
16	170-06B10-09	4019-51	Capscrew, Liner Retainer - 3/4-10 X 3-1/2 12PT ASTM 193 B16	282	72
17	181-11S00-00	6490-25	Liner Retainer Flange/Bushing		3
18	See Chart pg 4	2930-XX	Gasket, Liner		3
19	183-11S75-SS	8490-28	Wear Plate - Stainless Steel (available in carbon steel)		3
20	170-07A09-05	8488-5	Dowel Pin		6
21	170-07B09-06	4018-19	Capscrew, Suction Manifold - 7/8-9 X 2-1/2 Hvy Hex Head SAE J429	292	18
22	200-04N42-00	568-442	O-Ring, Suction Manifold		3
23	16-0145-P	1200G74	Crosshead Extension/Pony Rod		3
24	132-12C00-00	6274CWY	Rod Clamp, includes 25, 26, 27		3
25	202-1701	4020-29	Capscrew, Rod Clamp - 7/8-9 X 3-1/2 Hvy Hex Head Grade 8 Zinc Plated	455	6
26	208-008-ZP	LW875	7/8 Lock Washer		6
27	207-008-ZP	N/A	7/8 Flat Washer		6
28	1200120	1286CWYFP	Water Spray Pipe		3
29	131-12S00-00	6284-1	Sub Rod		3
30	170-14A06-06	1290-2	Connecting Stud, Sub and Piston Rod	2025	3
31	130-12S14-00	6278-25	Piston Rod with Nut (complete with 32)		3
32	170-14A06-01	API-4ESN	Nut, Piston Rod		3
33	301-0006	568-225	O-Ring, Piston Rod Seal		3
34	1.5-1.625-P	2932	Bushing, Piston		3
35	see insert	XX-BYY	Piston		3

Recommended torque type expressed in foot-pounds with use of moly grease

QUICK CHANGE DRILLING TECHNOLOGIES

Sur-Lock® Valve Cover

Save time and **eliminate the unsafe practices of using cheater pipes and sledge hammers** to tighten and loosen valve covers. In current practice, one rig hand will hold a pipe in the valve cover holes and another will swing a large sledge hammer at the pipe in order to loosen or tighten the assembly.

The Sur-Lock® Valve Cover system eliminates this unsafe practice and radically decreases the time it takes to remove valve covers, and replace valves and seats. **Sur-Lock requires no special tooling** and weighs about the same as a conventional valve cover assembly. **With the use of an impact wrench or just a torque wrench, the valve cover can be removed and replaced with minimal safety risk.**

Caliber® F-7500

F-1600 Compatible
7500 psi Two Piece Fluid End

SUR-LOCK

**HAMMERLESS™
TECHNOLOGY**

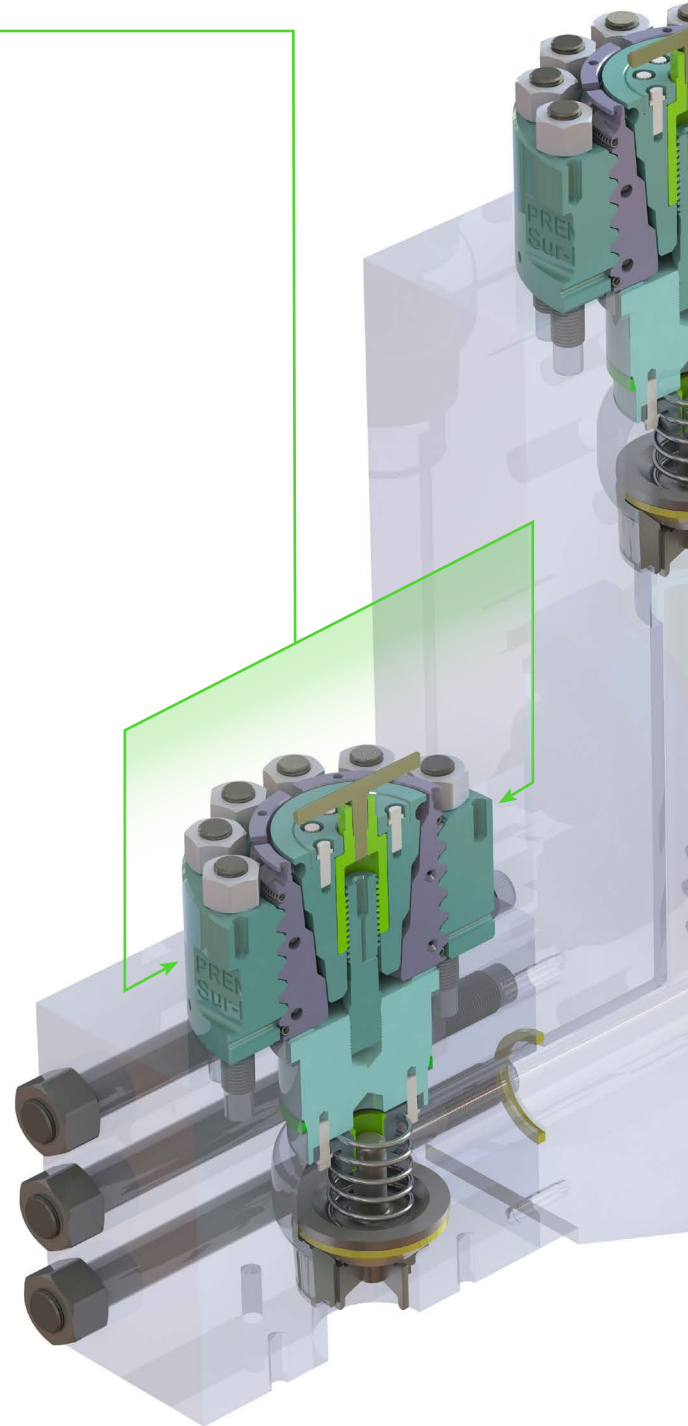



Sur-Lock® Rod Link

Save time and reduce failure points by eliminating the need for a hydraulic pump. **With our proprietary “taper lock” mechanism you simply use a standard wrench to unload the pins for removal.**

Our low profile water jet design can be used on pistons 4.5” and up. This system is fully interchangeable with P-Quip’s Rod Link System allowing you to effortlessly replace only the sub rod in “plug & play” fashion.

Sur-Lock® Liner Retainer

Designed to drastically reduce the amount of time it takes to change a liner, the Sur-Lock® Liner Retainer **eliminates the need for hammers** to generate the necessary torque required by integrating a torque multiplying pinion and bull gear into a conventional liner retention system. **We also reduced the weight of our liner nut to make change-outs safer and easier. The time to install a liner and tighten to the required torque is reduced to 45 seconds.**

SUR-LOCK[®] MODULE COMPONENTS

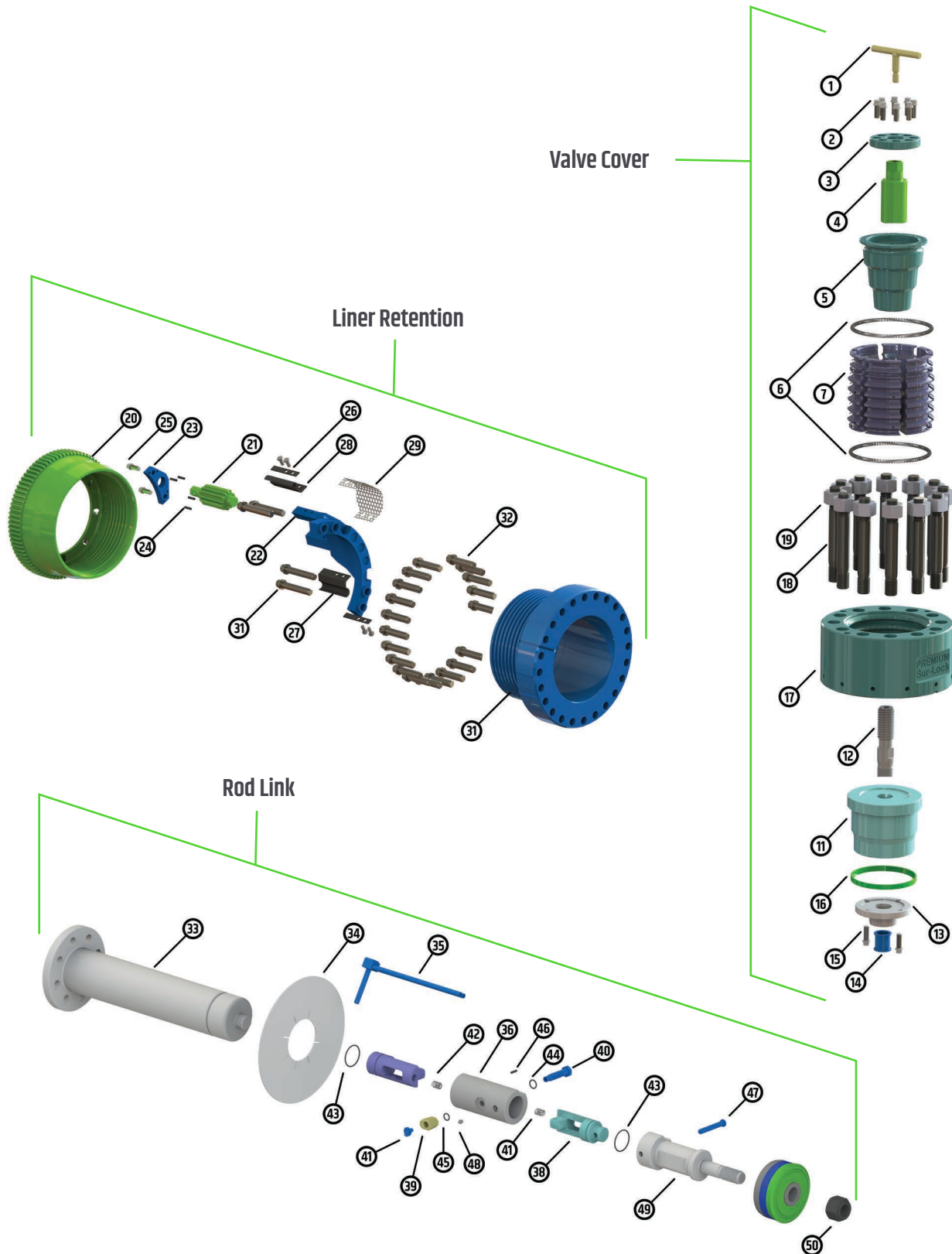

MODULE COMPONENTS

Item No.	Part Number	Part Description	Qty. Per Pump
Sur-Lock Valve Cover Assembly			
	627-0029	Cone Assembly (items 2-5)	6
1	627-0036	T-Handle	6
2	204-843	12PT Cap Screw	48
3	627-0026	Nut Retainer	6
4	627-0025	Cone Nut	6
5	627-0024	Locking Cone	6
	627-0027	Segment Assembly (items 6 - 10)	6
6	601-0047	Extension Spring	12
7	627-0023	Locking Segments (6 to a set)	6
8	601-0043	Dowel Pin .5" x 1.5"	72
9	601-0082	Connector Link	12
10	627-0038	Handle	6
	627-0028	Valve Cover Assembly (items 11 - 15)	6
11	627-0021	Valve Cover	6
12	627-0022	Valve Cover Stud	6
13	154-51S75-01	Valve Guide	6
14	206-44U07-00	Valve Guide Bushing	6
15	170-04B13-06	Valve Guide Capscrew	12
16	204-01U15-00	Valve Cover Seal	6
17	627-0020	Ring Flange	6
18	170-12A07-06S	Stud 1.250-7	72
19	170-12A07-00	Nut 1.250-7	72
Sur-Lock Liner Retention Assembly			
20	629-0075	Liner Nut	3
	629-0076	Pinion Bracket Assembly (items 21 - 29)	3
21	629-0079	Pinion	3
22	629-0077	Bracket	3
23	629-0078	Retainer	3
24	601-0121	Spring Pin .250 x 1.000	12
25	204-841	12PT Cap Screw .500-13UNC x 1.000	6
26	629-0109	Side Rail	6
27	629-0080	Guard Angle, Left Side	3
28	629-0081	Guard Angle, Right Side	3
29	629-0082	Pinion Guard	3
30	204-1287	12PT Screw .750-10UNC x 4.250	12
31	181-11S00-00	Liner Bushing	3
32	170-06B10-09	12PT Screw .750-10UNC x 4.250	60

Item No.	Part Number	Part Description	Qty. Per Pump
Sur-Lock Rod Link Assembly			
33	628-0021	Pony Rod	3
34	628-0036	Splash Shield	3
35	628-0030	Water Jet Assembly	3
	628-0033-N	Sub Rod Assembly (items 36 - 48)	3
36	628-0022	Housing	3
37	628-0023	Female Coupling	3
38	628-0024	Male Coupling	3
39	628-0150	Wedge Block	3
40	628-0151	Lock Screw	3
41	628-0152	Lock Screw Retainer	3
42	601-0052	Spring, 3/4"OD x 1" LG	6
43	3N7-2228	2-228 O-Ring, NBR 70 DURO	6
44	3N7-2211	2-211 O-Ring, NBR 70 DURO	3
45	3N7-2208	2-208 O-Ring, NBR 70 DURO	3
46	601-0113	Spring Pin, 1/4" x 7/8" Long	3
47a	628-0031	Pin, Standard 5" & Up	3
47b	628-0032	Pin, Low Profile 4.5" & Up	3
48	601-0009	Grease Fitting 1/8 NPT	
	628-0034	Piston Rod w/Nut (Items 49 & 50)	3
49	628-0020	Piston Rod	3
50	211-027	Piston Rod Nut	3

Tools (not shown)			Qty/Rig
51	601-0107	Torque Wrench (100-600 Ft Lbs)	1
52	627-0039	Jacking Spacer Ring	1
53	601-0188	Socket (1" Hex, 1" Drive)	1
54	601-0189	Torque Multiplier (1" Drive, 3:1 ratio)	1
55	628-0039	Rod Puller	1
56	628-0145	Rod Holder	1

RECOMMENDED: Torque type expressed in foot-pounds with use of moly grease

Since 2003, Premium Oilfield Technologies has been supplying quality products to the oil and gas industry.

Our core focus is to provide performance enhancing solutions that meet the strictest safety standards. We have developed, tested, and enhanced mud pump components, top drives, mud valves, RCD/MPD systems, shaker screens, and other drilling products that decrease downtime, improve safety, and perform in the toughest drilling environments.

Premium Oilfield Technologies has worldwide locations and operations in all of the U.S. major shale plays. Our field locations boast a crew of experienced technical sales representatives that visit each rig several times per month. Geographic positioning allows us to directly supply our products to more than 500 drilling rigs every day.

- ◆ Industry standard, fully interchangeable parts and systems
- ◆ Performance-enhancing hammerless technology
- ◆ Time saving safety enhancements
- ◆ Field-based rig site technical support
- ◆ Managed rig site inventory 24/7/365
- ◆ Strict onsite testing and quality assurance





**NO
TIME
FOR
DOWN
TIME**

CORPORATE

Premium Oilfield Technologies - USA

10600 W. Sam Houston Pkwy. North
Houston, TX 77064
T: +1 281.670.5200

USA MANUFACTURING & REPAIR

Patriot and Urethane

10600 W. Sam Houston Pkwy. North
Houston, TX 77064
T: +1 281.670.5228

Premium Drilling Equipment and Support

9841 Windmill Park Ln.
Houston, TX 77064
T: +1 281.670.5200

West Texas Operations - All Divisions

10207 West Industrial Ave.
Midland, TX 79706
T: +1 432.563.2328

Patriot Screens

4602 S. MacArthur Blvd.
Oklahoma City, OK 73179
T: +1 405.470.6553

NORTH AMERICA FIELD SALES, SERVICES AND REPAIR OFFICES

California / Colorado / Louisiana / New Mexico / North Dakota / Oklahoma / Pennsylvania / Texas / Utah
Wyoming / Leduc, Alberta

INTERNATIONAL

KUWAIT

Premium Oilfield Technologies
P.O. Box 721
Yarmouk, Kuwait 72658
T: +965 99679126
T: +965 66022296

UAE

Premium Oilfield Technologies Trading LLC
P.O. Box 89561
Dubai, UAE
T: +971 55 889 7210
T: +971 56 986 3834

INDIA

PMR Mud Riggers India Private Limited
S-Block-232, MIDC
Bhosari, Pune MH 411026
India

UAE

Premium Oilfield Technologies FZE Top Drive Solutions
S700, PLOT S30229
Jebel Ali Free Zone (South)
P.O. Box 262263
Dubai, UAE
T: +971 4 889 4897
T: +971 506587570

SAUDI ARABIA

Premium Mud Pumps Trading Est.
P.O. Box 956
Dammam, KSA
Postal Code: 31951
T: +966 50 0157516

UAE

Premium Oilfield Technologies FZE Mud Pump Solutions
S700, PLOT S30229
Jebel Ali Free Zone (South)
P.O. Box 262263
Dubai, UAE
T: +971 4 889 4897
T: +971 558897210



Premium Oilfield Technologies
Q1-3977
ISO 9001:2015
Certificate Number: 5028



sales@premiumoilfield.com
premiumoilfield.com

110524

SUR·LOCK

CALIBER

TRU·FLOW

PATRIOT™



LOGAN
Power Swivel